

KILLER INNOVATIONS

VELOCITY SLIDE FOR CZ P10 C

INSTALLATION, USE AND CARE INSTRUCTIONS

WARNING:

- 1. IMPORTANT! PLEASE READ AND FOLLOW THESE INSTALLATION INSTRUCTIONS. DAMAGE TO THE SLIDE MAY RESULT IF DIRECTIONS ARE NOT FOLLOWED.**
2. THIS PRODUCT SHOULD BE ASSEMBLED AND INSTALLED BY A COMPETENT GUNSMITH. **SERIOUS INJURY OR DEATH COULD RESULT FROM THE IMPROPER ASSEMBLY AND INSTALLATION OF THIS PRODUCT!**
3. ENSURE ALL FIREARM SAFETY'S ARE ADHERED TO AND THE FIREARM IS CLEAR AND UNLOADED BEFORE ATTEMPTING TO WORK ON THE FIREARM.
4. THE VELOCITY SLIDE FOR CZ P10 C IS DESIGNED FOR USE IN CZP10 C ONLY. PLEASE VERIFY YOU HAVE THE CORRECT MATCHING PISTOL AND GENERATION FOR YOUR SLIDE. **DO NOT ATTEMPT TO MODIFY THE SLIDE FOR ANY FIREARM OTHER THAN WHAT IT IS INTENDED FOR.**
5. IT IS HIGHLY RECOMMENDED YOU READ THE ENTIRETY OF THESE INSTRUCTIONS BEFORE THE SLIDE INSTALLATION IS STARTED.

PACKAGE CONTENTS:

YOUR SLIDE PACKAGE SHOULD INCLUDE THE FOLLOWING ITEMS:

- QTY: 1) KILLER INNOVATIONS SLIDE
- QTY: 1) KILLER INNOVATIONS ALUMINUM COVER PLATE (BLACK)
- QTY: 1) 6-32 X .265" , 5/64" OR 2MM STAINLESS HEX SCREW (BLUE)
- QTY: 1) 6-32 X .190" , 5/64" OR 2MM STAINLESS HEX SCREW (BLUE)
- QTY: 1) SHIM FOR TRIJICON RMR (BLACK)
- QTY: 1) EXTRACTOR PIN (STAINLESS)

INSTALLATION:

1. SAFETY:

ALWAYS CLEAR YOUR FIREARM OF ANY AMMUNITION AND MAKE SAFE BEFORE INSTALLING OR UNINSTALLING THIS SLIDE! ALWAYS FOLLOW PROPER FIREARM SAFETY WHEN USING OR WORKING ON YOUR PISTOL.

2. PARTS:

VERIFY ALL THE PARTS LISTED ABOVE CAME IN THE PACKAGING.

3. COVER PLATE:

THE COVER PLATE COMES PRE-INSTALLED WITH BLUE THREAD-LOCKER AND TORQUED TO 10 IN LB. **NOTE: DO NOT REMOVE COVER PLATE UNTIL REAR SIGHT IS INSTALLED. THIS IS VERY IMPORTANT IN PREVENTING DAMAGE TO THE SLIDE AND OR REAR SIGHT.**

1. TO RE-INSTALL COVER PLATE IF REMOVED, MAKE SURE THE SHORT SCREW IS INSTALLED IN THE RIGHT HOLE AND THE LONG SCREW IS INSTALLED IN THE LEFT HOLE WITH BLUE THREAD-LOCKER AT 10 IN LB.

4. IRON SIGHT INSTALLATION:

(KILLER INNOVATIONS IS NOT RESPONSIBLE FOR SLIDE OR SIGHT DAMAGE DUE TO SIGHT INSTALL ERRORS.)

REAR SIGHT (DAMAGE TO THE SLIDE MAY RESULT IF DONE INCORRECTLY)

1. MAKE SURE THE COVER PLATE IS INSTALLED BEFORE ATTEMPTING TO FIT AND INSTALL THE REAR SIGHT.
2. DO NOT USE EXCESSIVE FORCE AT ANY TIME INSTALLING THE REAR SIGHT. MEDIUM TAPS WITH A SMALL MALLET, OR MEDIUM FORCE USING SIGHT PUSHER TOOL IS ALL THAT SHOULD BE NEEDED. **DO NOT ATTEMPT TO REMOVE MATERIAL FROM THE SLIDE!**
3. REAR SIGHT SHOULD BE TUNED TO THE SLIDE BEFORE INSTALL. THEY ARE CUT BIG AND NEED TO BE ADJUSTED FOR A PROPER FIT. MAKE SURE TO FOLLOW THE SIGHT MANUFACTURES INSTALLATION INSTRUCTIONS IF THEY PROVIDE THEM.
4. MANY SIGHT MANUFACTURERS PROVIDE INSTALLATION VIDEOS ON THE INTERNET.
5. IF YOUR SIGHT MANUFACTURER DOESN'T PROVIDE INSTRUCTIONS, FOLLOW THE STEPS BELOW.
 - A. INCREMENTALLY REMOVE MATERIAL FROM THE BOTTOM SURFACE OF THE REAR SIGHT. MAKE SURE TO REMOVE MATERIAL EVENLY WHILE MAINTAINING FLATNESS. CHECK FREQUENTLY FOR A SNUG FIT THAT CAN EASILY BE PUSHED INTO THE SLIDE NOTCH BY HAND ABOUT 1/3 OF THE WAY BEFORE IT STOPS. FROM HERE IT SHOULD BE ABLE TO BE TAPPED OR PRESSED INTO POSITION WITH A SMALL MALLET & NYLON PUNCH OR SIGHT PUSHER TOOL. BE CAREFUL NOT TO REMOVE TOO MUCH MATERIAL SO THAT THE SIGHT CAN BE MOVED MORE THAN 1/3 THE WAY INTO THE SLIDE NOTCH BY HAND. THIS COULD RESULT IN A LOOSE SIGHT THAT MOVES WHEN IN USE. **THE REAR SIGHT SHOULD BE INSTALLED WITHOUT USING EXCESSIVE FORCE. IF YOU ARE UNSURE ABOUT THIS PROCESS, CONTACT YOUR LOCAL GUNSMITH FOR ASSISTANCE.**

FRONT SIGHT:

1. THE FRONT SIGHT POST SHOULD SLIDE IN AND LOCK USING A SCREW AND BLUE THREAD LOCKER AS PER SIGHT MANUFACTURES INSTRUCTIONS.

5. STAKING THE HOLE

1. USING THE SUPPLIED EXTRACTOR PIN, THE HOLE MUST BE STAKED ON THE BOTTOM SIDE BEFORE THE PIN IS INSTALLED FROM THE TOP. USING A METAL CENTER PUNCH AND A HAMMER, MAKE TWO STAKE DIMPLES ON OPPOSING SIDES OF THE HOLE. THE CENTER OF THE PUNCH SHOULD BE APPROXIMATELY .04" FROM THE EDGE OF THE HOLE. SEE PHOTO BELOW.

***NOTE ABOUT OUR EXTRACTOR PIN: THIS PIN IS A REDUCED OVERALL LENGTH. WHEN STARTING WITH AND OEM NON OPTICS READY SLIDE THE EXTRACTOR PIN IS LONGER AND WILL NOT WORK WITH THE COVER PLATE OR OPTIC INSTALLED.**



6. RED DOT SIGHT INSTALLATION:

1. IF INSTALLING **TRIJICON RMR**, THE COVER PLATE MUST BE REMOVED AND THE PROVIDED SHIM MUST BE INSTALLED. THE SHIM HAS ONE SLOTTED SIDE THAT SETS IN THE REAR BASE OF THE SLIDE. THIS SHIM IS ESSENTIAL FOR A SNUG FIT ON THE SLIDE. VERIFY THAT THE SCREW ON THE RIGHT SIDE DOES NOT INTERFERE WITH EXTRACTOR SPRING. IF THIS SITUATION OCCURS, THE SCREW MAY NEED TO BE TRIMMED TO PREVENT INTERFERENCE. BLUE THREAD LOCKER IS RECOMMENDED.
2. IF INSTALLING A **LEUPOLD DELTA POINT PRO**, THE COVER PLATE MUST BE REMOVED BUT THE PROVIDED SHIM WILL NOT BE REQUIRED. VERIFY THAT THE SCREW ON THE RIGHT SIDE DOES NOT INTERFERE WITH EJECTOR SPRING. IF THIS SITUATION OCCURS, SET SCREW MAY NEED TO BE TRIMMED TO PREVENT INTERFERENCE. BLUE THREAD LOCKER IS RECOMMENDED.
 - A. THE BLACK PLASTIC IRON SIGHT COVER LOCATED AT THE BACK OF THE SIGHT MAY NEED TO BE MODIFIED OR REMOVED FOR THE SIGHT TO FIT PROPERLY.

7. LUBRICATION:

1. BEFORE ASSEMBLING FIREARM. LIGHTLY LUBRICATE THE ENTIRE OUTSIDE OF THE BARREL WITH GREASE. DO NOT USE OIL AS THIS MAY DAMAGE YOUR BARREL'S FINISH. KILLER INNOVATIONS RECOMMENDS USING **LUCAS RED N TACKY #2** DURING BREAK IN.
2. LIGHTLY LUBRICATE THE SLIDE WITH GREASE IN THE AREAS INDICATED BELOW.

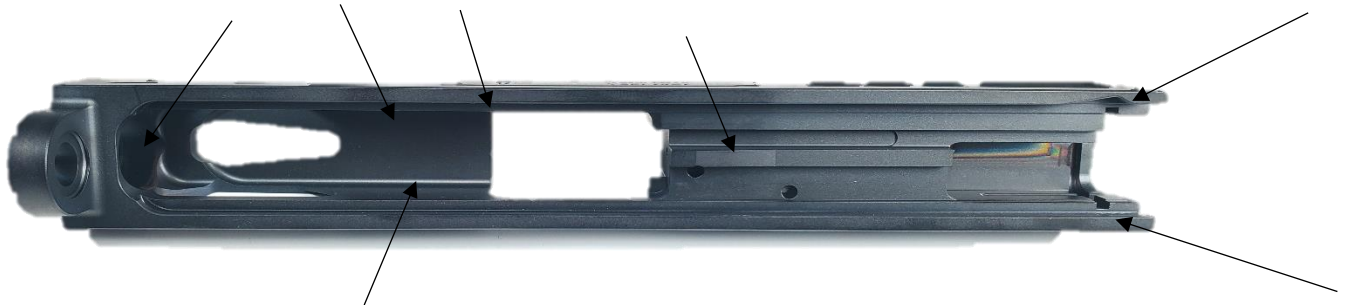

8. FINAL ASSEMBLY:

1. IF ANY PART OF YOUR GUN IS PAINTED, YOU MAY NEED TO REMOVE PAINT IN ANY AREA THAT CREATES DRAG OR EXCESSIVE FRICTION BETWEEN MOVING PARTS.
2. THE FIREARM CAN NOW BE REASSEMBLED IN REGULAR FASHION. BE SURE TO PERFORM ALL PROPER FUNCTION AND SAFETY TESTS BEFORE TESTING WITH AMMUNITION.

9. BREAK IN PROCEDURES:

THERE ARE A FEW STEPS THAT WE RECOMMEND BE FOLLOWED DURING THE BREAK IN PERIOD.

BREAK IN TIMES CAN VARY DEPENDING ON WHAT FINISHES YOUR PARTS HAVE AND HOW NEW THEY ARE.

1. MAKE SURE YOUR GUN IS LUBRICATED WITH GREASE AS LISTED ABOVE DURING BREAK IN.
2. DO NOT ATTEMPT TO RUN A COMPENSATOR UNTIL THE FIREARM IS FULLY BROKEN IN.
3. INSTALL THE FACTORY WEIGHT SPRING DURING THE BREAK IN PERIOD.
4. RUNNING A MINIMUM OF 400 ROUNDS OF QUALITY AMMUNITION IS RECOMMENDED FOR OPTIMAL BREAK IN.
5. FULLY DISASSEMBLE AND CLEAN THE ENTIRE GUN.
6. RE-LUBRICATE WITH GUN OIL AFTER BREAK IN IS COMPLETED.
7. YOUR GUN SHOULD BE READY FOR REGULAR USE!

THANK YOU FOR CHOOSING KILLER INNOVATIONS! WE APPRECIATE YOUR SUPPORT!